

International
IR Rectifier

REFERENCE DESIGN

IRAUDAMP1

International Rectifier • 233 Kansas Street, El Segundo, CA 90245 • USA

High Power Class D Audio Power Amplifier using IR2011S



High Power Class D Audio Power Amplifier using IR2011S

Features

- Complete Analog Input Class D Audio Power Amplifier
- 500W + 500W Peak Stereo (2CH) Output
- THD+N=0.008% @1kHz, 100W, 4Ω
- High Efficiency 93% @350W, 1kHz, 4Ω
- Simple Self Oscillating Half-Bridge Topology
- Includes all Local House-keeping Power Supplies
- Protection Functions
- Wide Operating Supply Voltage Range $\pm 25 \sim 60V$
- Immune to Power Supply Fluctuations

Description

The IRAUDAMP1 is an example of a simple complete class D audio power amplifier design using the IR2011S, high speed high voltage gate driver IC. The design contains protection functions and house keeping power supplies for ease of use. This reference design is intended to demonstrate how to use the IR2011S, implement protection circuits, and design an optimum PCB layout.

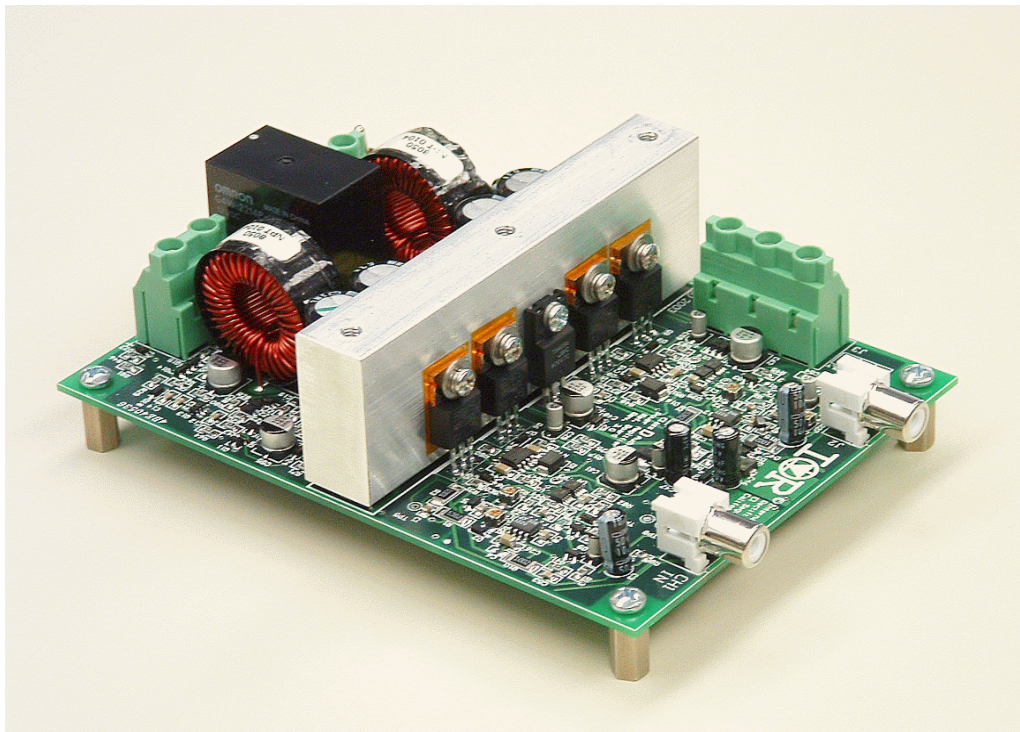

Specifications

$\pm V_{cc} = \pm 50V$, $R_L = 4\Omega$ unless otherwise noted.

Output Stage Topology	Half Bridge	
Modulator	Self Oscillating, 2nd order Sigma-Delta Modulation, Analog Input	
IR Devices Used	IR2011S Gate Driver IRFB23N15D MOSFET	
Switching Frequency	400kHz (Adjustable)	No signal
Rated Output Power	250W + 250W 350W + 350W 370W + 370W (Peak Power) 500W + 500W (Peak Power)	1kHz, THD=1.0% 1kHz, THD=10% 1kHz, THD=1.0%, $\pm 60V$ 1kHz, THD=10%, $\pm 60V$
THD+N	0.008%	1kHz, 100W, AES-17 LPF
Efficiency	93%	1kHz, 350W, Class D stage
S/N	115dB	IHF-A Weighted, BW=20kHz
Damping Factor	200	8Ω, 1KHz
Frequency Response	3Hz ~ 40kHz (-3dB)	
Channel Separation	100dB 80dB	100Hz 10kHz
Minimum Load Impedance	4Ω	
Power Supply	$\pm 50V$, (operational $\pm 25V \sim \pm 60V$)	
Quiescent Current	+75mA, -125mA	
Dimensions	4.0"(W) x 5.5"(D) x 1.5"(H)	

Note: Specifications are typical and not guaranteed.

Instructions

Connection Diagram

A typical test setup is shown in Fig.1.

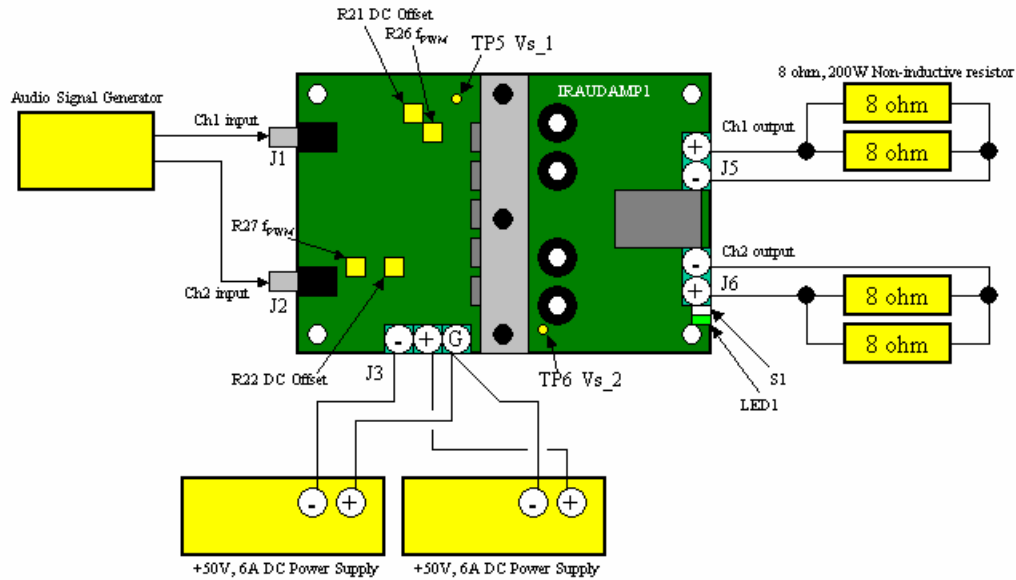

Fig.1 Test Setup

Pin Description

J1	CH-1 IN	Analog input for CH-1
J2	CH-2 IN	Analog input for CH-2
J3	POWER	Positive and negative supply
J5	CH-1 OUT	Output for CH-1
J6	CH-2 OUT	Output for CH-2

Power-on Procedure

1. Apply $\pm 50V$ at the same time
2. Apply audio signal

Note: Improper power on procedure could result start up failure.

Power-off Procedure

1. Remove audio input signal
2. Turn off $\pm 50V$ at the same time

Resetting Protection

1. Turn off $\pm 50\text{V}$ at the same time
2. Wait until supply voltage drops to less than 5V
3. Apply $\pm 50\text{V}$ at the same time
4. Apply audio signal

Power Supply

The IRAUDAMP1 requires a pair of symmetric dual power supplies ranging from $\pm 25\text{V}$ to $\pm 60\text{V}$. A regulated power supply is preferable for performance measurements, but not always necessary. The bus capacitor, C38-41 on the board along with high frequency bypass C31, C32, C35, and C36; are designed to take care only of the high frequency ripple current components from the switching action. A set of bus capacitors having enough capacitance to handle the audio ripple current must be placed outside the board if an unregulated power supply is used.

Bus Pumping

Since the IRAUDAMP1 is a half bridge configuration, the bus pumping phenomenon occurs when the amplifier outputs low frequency signal is below 100Hz. The bus pumping phenomenon is unavoidable; significant bus voltage fluctuations caused by a reverse energy flow coming back to the power supply from the class D amplifier. This might cause an unacceptable instability condition in the feedback system of a power supply.

The bus pumping becomes worse in the following conditions.

- lower the output frequency
- lower the load impedance
- higher the output voltage
- smaller the bus capacitance in bus capacitors

If the bus voltage become too high or too low, the IRAUDAMP1 will shutdown the switching operation, and remain in the off condition until resetting the protection using the method described above.

One of the easiest countermeasures is to drive both of the channels out of phase so that the reverse energy from one channel is consumed by the other, and does not return to the power supply.

Input Audio Signal

A proper input signal is an analog signal below 20kHz, up to 5Vrms, having a source impedance of less than 600 Ω . A 30-60kHz input signal can cause LC resonance in the output LPF, resulting in an abnormally large amount of reactive current flowing through the switching stage. The IRAUDAMP1 has a C-R network to dump the resonant energy and protect the board in such a condition. However, these sub-sonic input frequencies should be avoided.

Load Impedance

The IRAUDAMP1 is designed for a load impedance of 4 Ω and larger. The frequency response will have a small peak at the corner frequency of the output LC LPF if the loading impedance is higher than 4 Ω . The IRAUDAMP1 is stable with capacitive loading, however, it should be realized that the frequency response will be degraded by a heavy capacitive loading of more than 0.1 μF .

Adjustments of DC offset and Switching Frequency

Component Number	Adjustment
R10	DC offset for CH-1
R26	Switching Frequency for CH-1
R22	DC offset for CH-2
R27	Switching Frequency for CH-2

Adjustments have to be done at an idling condition with no signal input.

Note: The PWM switching frequency in this type of self oscillating scheme greatly impacts the audio performances, especially in the case where two or more channels are in close proximity.

Thermal Considerations

The IRAUDAMP1 utilizes a relatively thick aluminum block heatsink for peak power output handling capabilities. It can handle continuous 1/8 of the rated power, which is generally considered to be a normal operating condition in safety standards, for a considerable length of time such as one hour. The size of the heatsink, however, is not sufficient to handle continuous rated power.

Fig.2 shows the relationship between total power dissipation and temperature rise at equilibrium. If testing requires running conditions with continuous power a higher than 1/8 of the rated power, then, attach extensions to the top of the heatsink using three M4 screw taps prepared for this purpose. Please note that the heatsink is electrically connected to the GND pin.

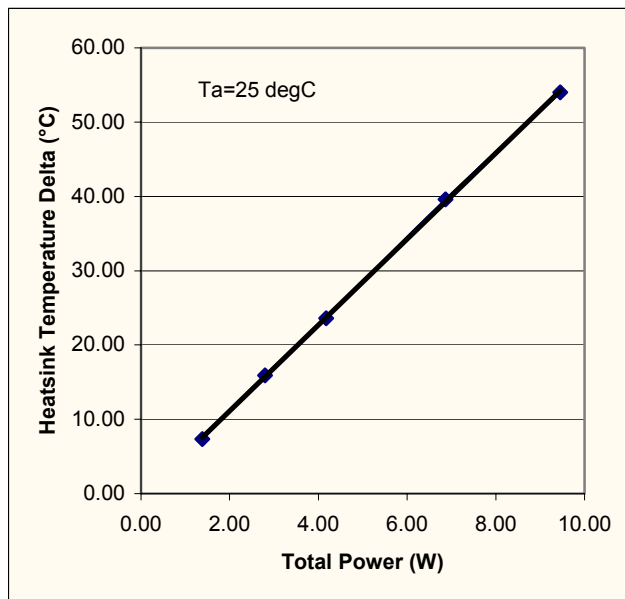

Fig.2 Heatsink Thermal Characteristic at Equilibrium

Functional Description

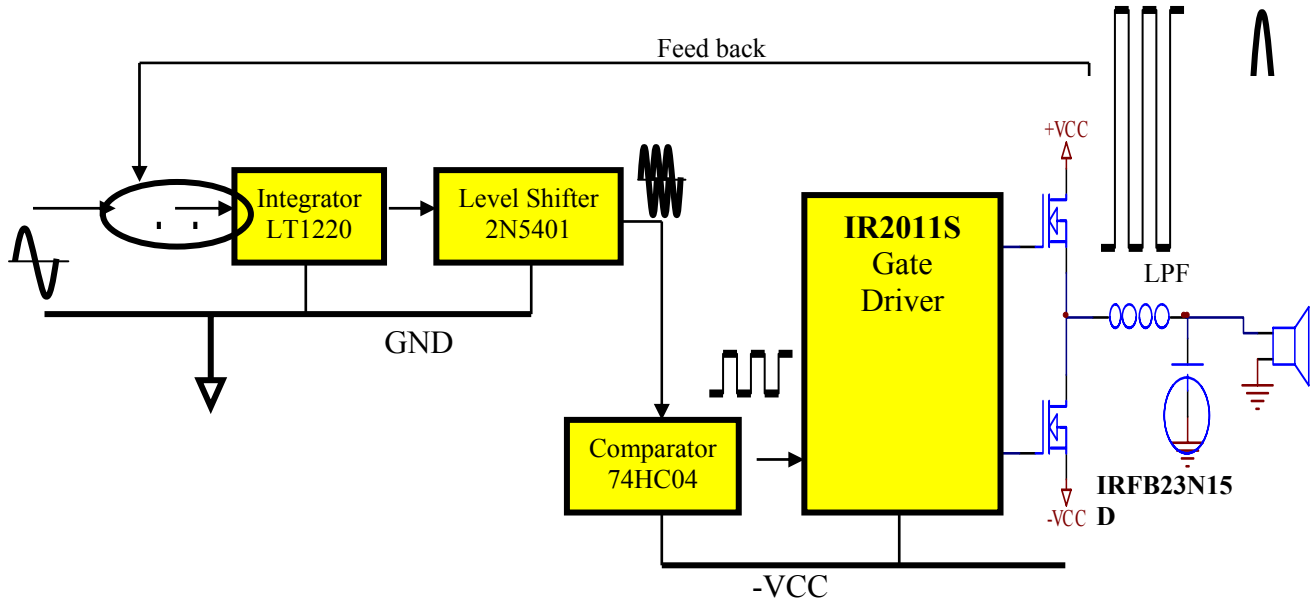

Fig. 3 Simplified Block Diagram of Amplifier

Self Oscillating PWM modulator

The IRAUDAMP1 class D audio power amplifier is based on a self oscillating type PWM modulator for the lowest component count and a robust design. This topology is basically an analog version of a 2nd order sigma delta modulation having a class D switching stage inside the loop. The benefit of the sigma delta modulation in comparison to the carrier signal based modulator is that all the error in the audible frequency range is shifted away into the inaudible upper frequency range by nature of its operation, and it can apply a sufficient amount of correction. Another important benefit of the self-oscillating modulator is that it will cease operation if something interrupts the oscillating sequences. This is generally beneficial in a class D application because it makes the amplifier more robust.

Looking at CH-1 as an example, OP amp U1 forms a front end 2nd order integrator with C17 & C18. This integrator receives a rectangular waveform from the class D switching stage and outputs a quadratic oscillatory waveform as a carrier signal. To create the modulated PWM, the input signal shifts the average value of this quadratic waveform, through R10, so that the duty varies according to the instantaneous value of the analog input signal. The level shift transistor Q1 converts the carrier signal from a voltage form into a current form and sends it to the logic gates sitting on the negative DC bus via the level shift resistor R44, which converts the signal back into a voltage form. The signal is then quantized by the threshold of the CMOS inverter gate U2. The PWM signal out of the inverter is split into two signals, with opposite polarity, one for high side MOSFET drive signal, the other for the low side MOSFET drive signal. The dual AND gates of U4 are used to implement the shutdown function, a high shutdown signal will ensure the outputs of the AND gates are low which in turn ensures the inputs to the gate driver are low.

Under normal conditions the SD signal is low and the drive signal are passed directly through the AND gates to the IR2011S gate driver.

The IR2011 drives two IRFB23N15D MOSFETs in the power stage to provide the amplified Digital PWM waveform.

The amplified analog output is recreated by demodulating the amplified PWM. This is done by means of the LC Low Pass Filter formed by L1 and C51, which filters out the class D switching signal.

Switching Frequency

The self oscillating frequency is determined by the total delay time inside the loop. The following parameters affect the frequency.

- Delay time in logic circuits
- The gate driver propagation delay
- MOSFET switching speed
- Integration time constant in the front end integrator, e.g. R1, R23, R26, C17, and C18 for CH-1.
- Supply Voltages

Gate Driver

The IRAUDAMP1 uses the IR2011S gate driver IC which is suitable for high speed, high speed switching applications up to 200V. In this design, the difference between t_{on} and t_{off} is used to generate a dead-time (a blanking time in between the on state of the two MOSFETs). Because of this, there is no gate timing adjustment on the board.

MOSFET Gate Resistor

In order to add a little more dead-time and compensate for the finite switching transient time in the MOSFET, a schottky diode is added in parallel with the gate resistor. The gate resistor (R31 and R50 in CH-1) adds about 10nS of delay time at turn on by limiting the gate charging current to the IRFB23N15D. The schottky diode bypasses the gate resistor in the gate discharge path, so that there is no falling edge delay. The delay at the rising edge adds dead time.

Startup Circuit

A self oscillating scheme contains class D switching stage that requires a start-up triggering signal to charge the high side bootstrap capacitor. The starter circuits, Q9 and Q10, detect the rising edge of $-V_{cc}$ and turn the low side MOSFETs on for about 200mS to charge the bootstrap capacitors C23 and C24, then release the loop allowing the oscillation to start.

Housekeeping Voltage Regulators

The IRAUDAMP1 contains following regulators to accommodate all the necessary functions on the board.

Regulator	Component #	Usage
+5V	Q18	OP Amps in the modulator
-5V	Q17	OP Amps in the modulator, Startup circuit
-Vcc+5V	U13, U14	Logic ICs
-Vcc+12V	U11	Gate driver IC, Protection circuits

Protection

The IRAUDAMP1 includes protection features for overvoltage (OVP), overcurrent (OCP), and DC current protection. All of the protection uses OR logic so that any of the protection features when activated will disengage the output relay to cut off the load and protect the speakers. OCP and OVP functions are latched, DC protection is unlatched. To reset the protection, the bus voltage has to be reset to zero volts before re-applying power. The protection circuitry will also shutdown the amplifier if a fault condition is detected.

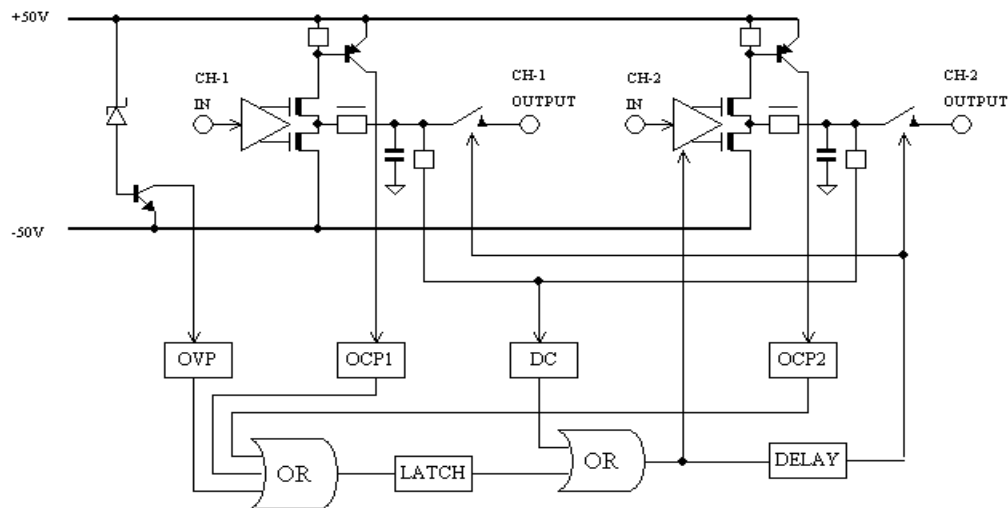

Fig.4 Functional Block Diagram of Protection

DC protection

DC voltage output protection is provided to protect the speakers from DC current. This abnormal condition occurs only when the power amplifier fails and one of the MOSFETs remains in the ON state. DC protection is activated if the output has more than $\pm 3V$ DC offset. DC protection is unlatched, and the amplifier will resume normal operation about 2 seconds after a fault condition has been removed.

Over Current Protection

Over Current Protection will activate and shut down the entire amplifier if the amount of current sensed at the positive power supply in either channel exceeds the preset value. If an overcurrent condition occurs, the voltage generated across a shunt resistor turns on the OCP detection transistors, Q2 and Q4 to send a signal to the protection logic.

Over Voltage Protection

Over Voltage Protection shuts down the amplifier if the bus voltage between $-V_{cc}$ and $+V_{cc}$ exceeds 126V, the threshold is determined by the sum of the zener voltages of Z1, Z2, and Z3. OVP protects the board from the bus pumping phenomena which occurs at very low audio signal frequencies by shutting down the amplifier.

Power On/Off Sequence Timing

The IRAUDAMP1 is a robust design that can handle any power up/down sequence. However, symmetrical power up is recommended to properly initiate the self oscillation. In order for the unit to startup correctly, the negative power supply has to be initialized from zero volts.

Fig.5 shows a preferred power up sequence. At start-up, a DC output voltage appears at the output of the LPF due to the charging of the bootstrap capacitors. To avoid this unwanted DC output signal being fed to the load, the output relay RLY1 engages approximately 2 seconds after the startup condition is completed. Fig 6 below shows the start-up timing with the audio output not being activated until approximately 2 seconds after the power supplies are stable and the amplifier has reached steady state operation.

Fig.6 Preferred Power Up/Down Sequence

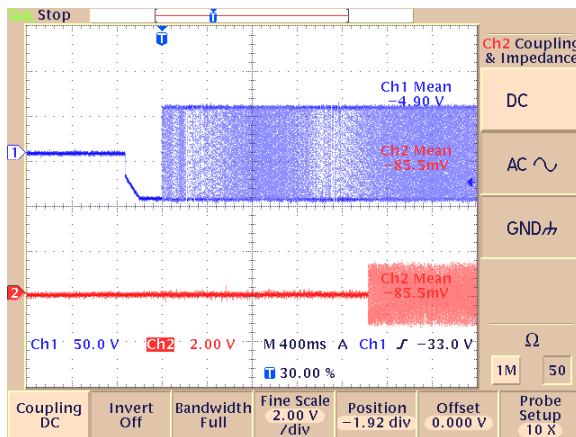

Fig.5 Start-up Timing

(BLU: Switching, RED: Audio Output)

Typical Performance

$\pm V_{cc} = \pm 50V$, $R_L = 4\Omega$ unless otherwise noted.

International Rectifier A-A FREQUENCY RESPONSE 02/25/04 10:06:24

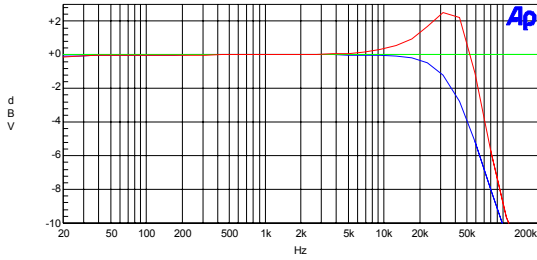

Sweep	Trace	Color	Line Style	Thick	Data	Axis	Comment
1	1	Blue	Solid	1	Anlr.AmplINormalize	Left	4 ohm
2	1	Red	Solid	1	Anlr.AmplINormalize	Left	8 ohm
2	2	Green	Solid	1	Anlr.LevelBNormalize	Left	

A-A-FREQ RESP at2

Fig.6 Frequency characteristics
Frequency

International Rectifier A-A CROSSTALK or SEPARATION vs FREQUENCY 02/25/04 17:05:17

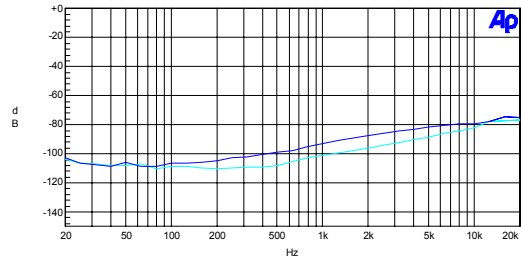

Sweep	Trace	Color	Line Style	Thick	Data	Axis	Comment
1	1	Blue	Solid	1	Anlr.Crosstalk	Left	4 ohm
1	2	Cyan	Solid	1	Anlr.Crosstalk	Left	4 ohm

A-A.XTALK VS FREQ.at2

Fig.7 Channel Separation v.s.

International Rectifier A-A THD+N vs FREQUENCY 02/27/04 18:39:45
4Ω Loading, $\pm V_{cc} = \pm 25V, \pm 30V, \pm 40V, \pm 50V, \pm 60V$

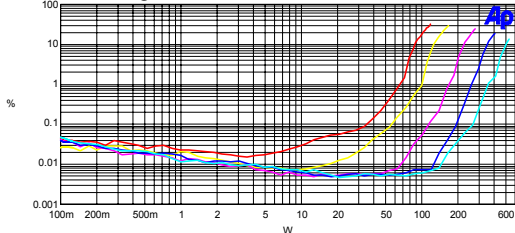

Sweep	Trace	Color	Line Style	Thick	Data	Axis	Comment
1	1	Yellow	Solid	2	Anlr.THd+N Ratio	Left	30v
2	1	Red	Solid	2	Anlr.THd+N Ratio	Left	25v
3	1	Magenta	Solid	2	Anlr.THd+N Ratio	Left	40v
4	1	Blue	Solid	2	Anlr.THd+N Ratio	Left	50v
5	1	Cyan	Solid	2	Anlr.THd+N Ratio	Left	60v

A-A THD+N VS power.at2

Fig.8 THD+N v.s. Output Power

International Rectifier A-A THD+N vs FREQUENCY 02/25/04 11:17:24
4Ω Loading, $\pm V_{cc} = \pm 50V, 1W / 50W / 100W$

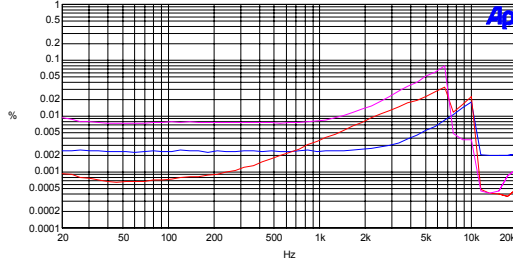

Sweep	Trace	Color	Line Style	Thick	Data	Axis	Comment
1	1	Blue	Solid	1	Anlr.THd+N Ratio	Left	rev.3.3, 1W, 4 ohm
2	1	Red	Solid	1	Anlr.THd+N Ratio	Left	50W
3	1	Magenta	Solid	1	Anlr.THd+N Ratio	Left	100w

A-A THD+N VS FREQ.at2

Fig.9 THD+N v.s. Frequency (4Ω)

International Rectifier A-A FFT SPECTRUM ANALYSIS 02/25/04 18:11:00

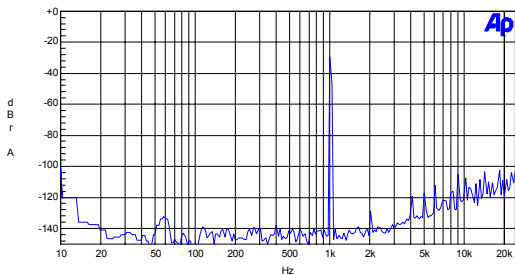

Sweep	Trace	Color	Line Style	Thick	Data	Axis	Comment
1	1	Blue	Solid	1	Fit.Ch.1 Ampl	Left	1V, 4 ohm, referenced to 30v

A-A FFT at2

Fig.10 Spectrum
(1kHz, 1V, 4Ω, $f_{sw} = 400KHz$)

International Rectifier A-A FFT SPECTRUM ANALYSIS 02/25/04 18:08:39

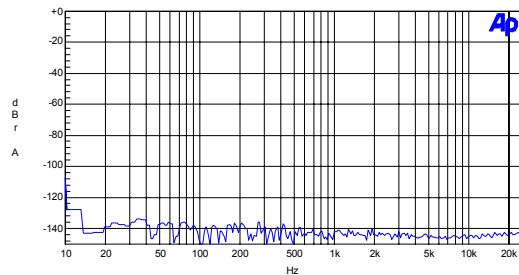

Sweep	Trace	Color	Line Style	Thick	Data	Axis	Comment
1	1	Blue	Solid	1	Fit.Ch.1 Ampl	Left	4 ohm, referenced to 30V

A-A FFT at2

Fig.11 Residual Noise Spectrum
(no signal, 4Ω, $f_{sw} = 400KHz$)

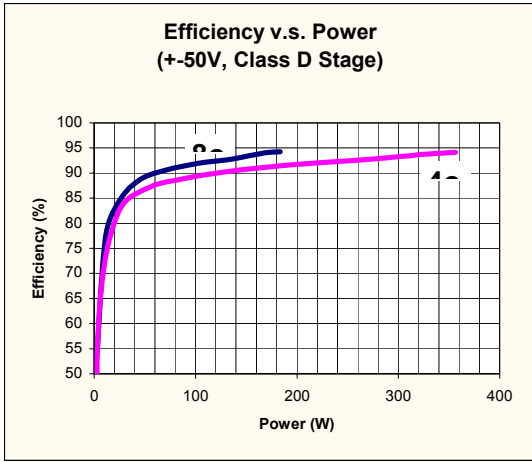

$\pm V_{CC} = \pm 50V$, $f_{SW} = 400kHz$

Fig.12 Efficiency v.s. Output Power

Typical Switching Waveforms

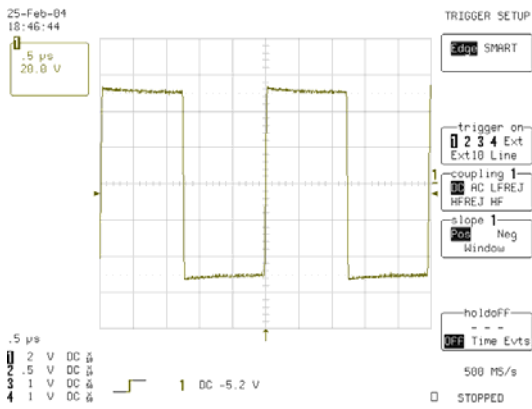

(a) 20v/div, 0.5μs/div

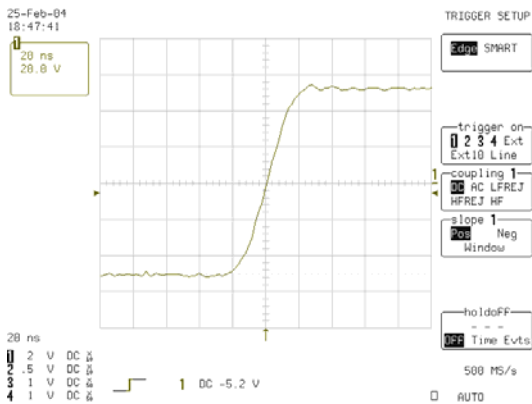

(b) 20nS/div, Rising Edge

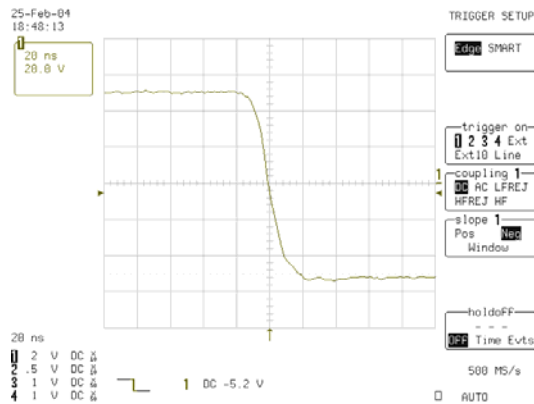

(c) 20nS/div, Falling Edge

Fig.13 Switching Waveform at Output Node (TP5)

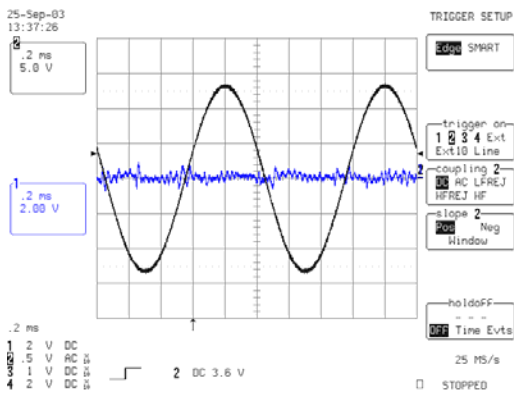

(a) 50W / 4Ω, 1KHz, THD+N=0.0078%
Distortion Waveform

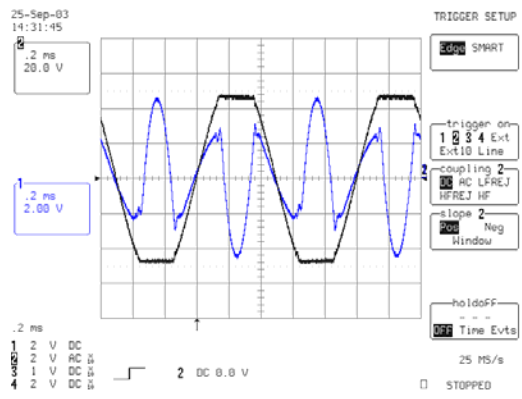

(b) 352W / 4Ω, 1KHz, THD+N=10% Fig.14

Schematic Diagrams

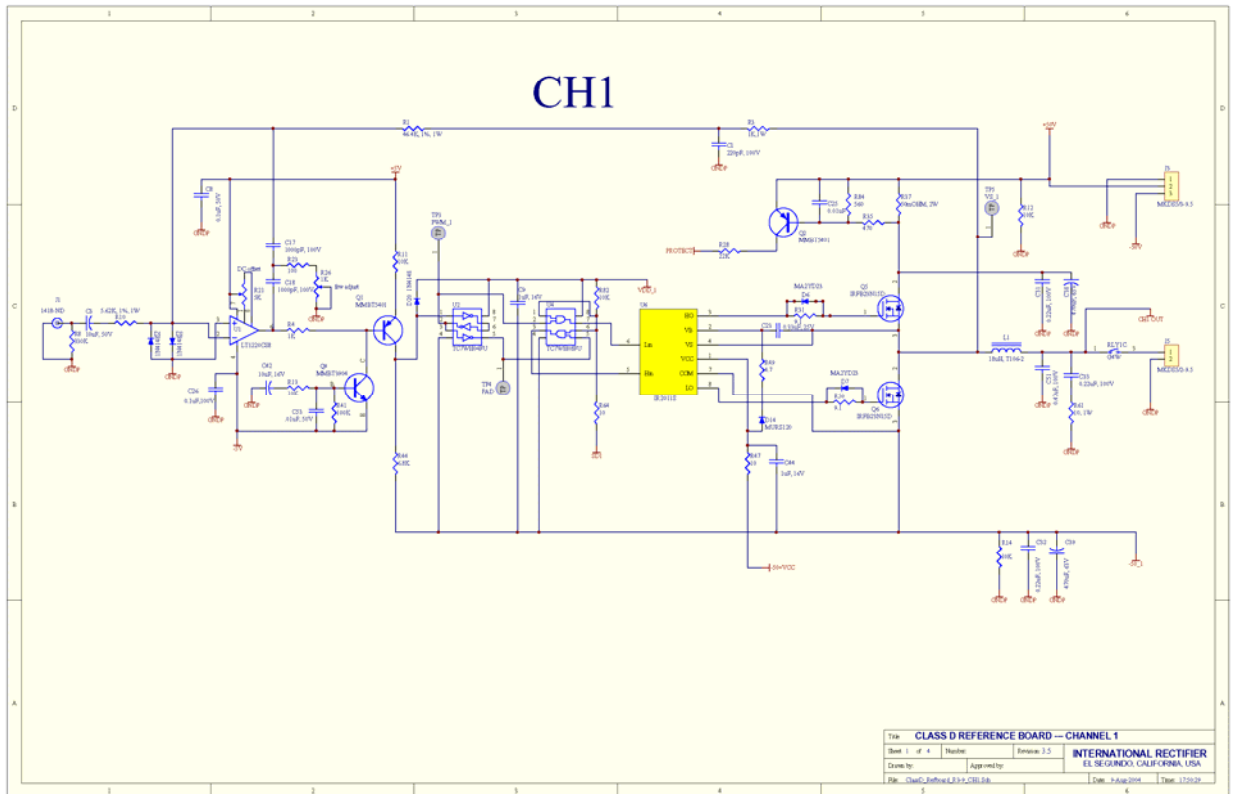

PS

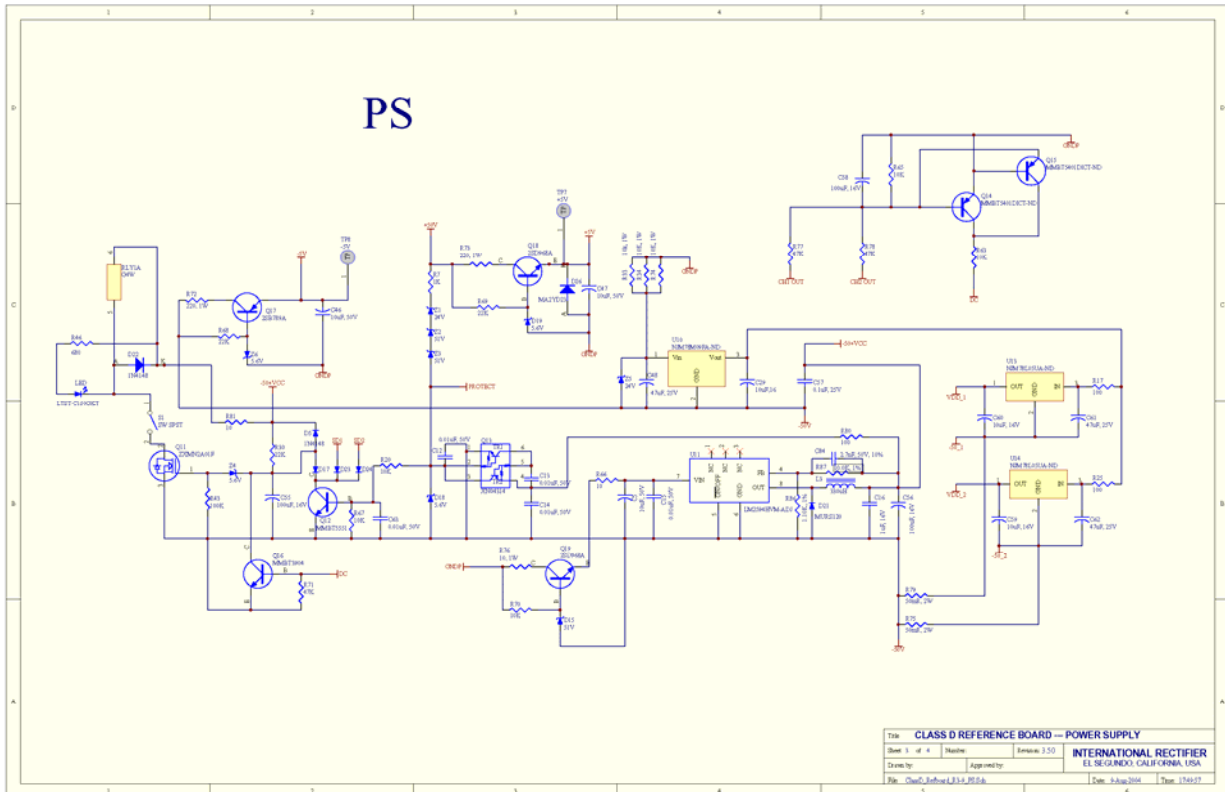

Title CLASS D REFERENCE BOARD — POWER SUPPLY			
Sheet 1 of 4	Number	Revision 3.50	INTERNATIONAL RECTIFIER EL SEGUNDO, CALIFORNIA, USA
Drawn by	Approved by		
File: Ch04_01refwrk1313_PS.Dwg	Date: 3-23-2004	Time: 17:45:57	

Bill of Materials

IRAUDAMP1_REV3.9_BOM							
Qty	Vender	Distr P/N	Manufacturer	Manuf. Part#	Designator	Part Type	Description
2	Consigned	IR2011S			U6,U7	IR2011S	High and Low Side Driver
4	Consigned	IRFB23N15D			Q6,Q5,Q8,Q7	IRFB23N15D	N-Channel MOSFET
3	Consigned	MURS120DICT-ND			D14,D16,D21	MURS120DICT	fast recovery diode
1	custom made	IRDAMP-01-103				Heatsink	Heatsink
2	custom made	NPT0104			L2,L1	18uH	inductor, T-106-2, t=37, AWG18
1	Digikey	160-1169-1-ND	Lite-On Trading USA, Inc.	LTST-C150GKT	LED1	LTST-C150GKT	LED, SMD
11	Digikey	1N4148WDICT-ND	Diodes Inc.	1N4148W-7	D1,D2,D3,D4,D5,D17,D20,D23,D24,D25,D22	1N4148WDICT-ND	DIODE
2	Digikey	277-1271-ND	Phoenix Contact	1714971	J6,J5	MKDS5/2-9.5	terminal 2P
1	Digikey	277-1272-ND	Phoenix Contact	1714984	J3	MKDS5/3-9.5	terminal 3P
1	Digikey	2SB0789A0LCT-ND	Panasonic	2SB0789A0L	Q17	2SB789A	2SB789A, SMD
2	Digikey	2SD0968A0LCT-ND	Panasonic	2SD0968A0L	Q18,Q19	2SD968A	2SD968A, SMD
2	Digikey	BZT52C24-7DICT-ND	Diodes Inc.	BZT52C24-7	Z5,Z1	24V	zener diode, SMD
3	Digikey	BZT52C51-7DICT-ND	Diodes Inc.	BZT52C51-7	D15,Z3,Z2	51V	zener diode
4	Digikey	BZT52C5V6-7DICT-ND	Diodes Inc.	BZT52C5V6-7	D19,Z6,D18,Z4	5.6V	zener diode, SMD
2	Digikey	CP-1418-ND	GUI Inc	RCJ-041	J1,J2	CP-1418-ND	CONN_RCA JACK
3	Digikey	H244-ND	Building Fasteners	INT LWZ 008		Washer	washer lock int tooth #8 zinc
1	Digikey	H346-ND	Building Fasteners	PMS 440 0050 PH		Screw	Screw, 4-40 Philips, L=0.5"
4	Digikey	H354-ND	Building Fasteners	PMS 632 0025 PH		Screw	6-32 x 1/4, Philips
3	Digikey	H749-ND	Building Fasteners	MPMS 004 0012 PH		Screw	Screw, M4 Philips, L=12mm
1	Digikey	LM2594HVM-ADJ-ND	National Semiconductor	LM2594HVM ADJ	U11	LM2594HVM-ADJ	Step-Down Voltage Regulator
2	Digikey	LT1220CS8-ND	Linear Technology	LT1220CS8	U12,U1	LT1220CS8	OP AMP
1	Digikey	M9715CT-ND	J W Miller Magnetics	PM3316-331M	L3	330uH	inductor, SMD
5	Digikey	MA2YD2300LCT-ND	Panasonic	MA2YD2300L	D9,D6,D7,D8,D26	MA2YD23	DIODE
3	Digikey	MMBT3904DICT-ND	Diodes Inc.	MMBT3904-7	Q10,Q9,Q16	MMBT3904DICT-ND	2N3904, SMD
6	Digikey	MMBT5401DICT-ND	Diodes Inc.	MMBT5401	Q14,Q15,Q2,Q3,Q4,Q1	MMBT5401DICT-ND	2N5401, SMD
1	Digikey	MMBT5551DICT-ND	Diodes Inc.	MMBT5551DICT-ND	Q12	MMBT5551DICT-ND	2N5551, SMD
2	Digikey	NJM78L05UA-ND	NJR	NJM78L05UA	U13,U14	NJM78L05UA-ND	Positive Voltage Regulator
1	Digikey	NJM78M09FA-ND	NJR	NJM78M09FA	U10	NJM78M09FA-ND	Positive Voltage Regulator
1	Digikey	P1.0KACT-ND	Panasonic	ERJ-6GEYJ102V	R7	1K	resistor, 0805
5	Digikey	P100ACT-ND	Panasonic	ERJ-6GEYJ101V	R17,R25,R23,R24,R80	100	resistor, 0805
3	Digikey	P100KACT-ND	Panasonic	ERJ-6GEYJ104V	R43,R41,R42	100K	resistor, 0805
7	Digikey	P10ACT-ND	Panasonic	ERJ-6GEYJ100V	R47,R19,R66,R48,R64,R66,R81	10	resistor, 0805
12	Digikey	P10KACT-ND	Panasonic	ERJ-6GEYJ103V	R70,R43,R18,R20,R12,R14,R13,R65,R83,R82,R63,R67	10K	resistor, 0805
5	Digikey	P22KACT-ND	Panasonic	ERJ-6GEYJ223V	R68,R69,R30,R29,R28	22K	resistor, 0805
2	Digikey	P330KACT-ND	Panasonic	ERJ-6GEYJ334V	R8,R9	330K	resistor, 0805
2	Digikey	P4.7ACT-ND	Panasonic	ERJ-6GEYJ4R7V	R49,R51	4.7	resistor, 0805
2	Digikey	P470ACT-ND	Panasonic	ERJ-6GEYJ471V	R35,R36	470	resistor, 0805
3	Digikey	P47KACT	Panasonic	ERJ-6GEYJ473V	R71,R77,R78	47K	resistor, 0805
1	Digikey	P680ACT-ND	Panasonic	ERJ-6GEYJ681V	R46	680	resistor, 0805
2	Digikey	P560ACT-ND	Panasonic	ERJ-6GEYJ561V	R84,R85	560	resistor, 0805

4	Digikey	P9.1ACT-ND	Panasonic	ERJ-6GEYJ9R1V	IRAUDAMP1_REV3.9RBZ031,R50,R52	9.1	resistor, 0805
9	Digikey	PCC103BNCT-ND	Panasonic	ECJ-2VB1H103K	C27,C25,C14,C15,C12,C13,C54,C53,C63	0.01uF, 50V	capacitor, 0805
3	Digikey	PCC1828CT-ND	Panasonic	ECJ-2VB1E104K	C57,C10,C8	0.1uF, 25V	capacitor, 0805
3	Digikey	PCC1882CT-ND	Panasonic	ECJ-3YB1C105K	C16,C45,C44	1uF, 16V	capacitor, 1206
2	Digikey	PCC1889CT-ND	Panasonic	ECJ-3VB1E334K	C24,C23	0.33uF, 25V	capacitor, 1206
2	Digikey	PCC1966CT-ND	Panasonic	ECJ-2VC2A221J	C1,C2	220pF, 100V	capacitor, 0805
4	Digikey	PCC1970CT-ND	Panasonic	ECJ-2VC2A102J	C20,C21,C17,C18	1000pF, 100V	capacitor, 0805
2	Digikey	PCC2239CT-ND	Panasonic	ECJ-3YB1A104K	C28,C26	0.1uF, 100V	capacitor, 1206
2	Digikey	PCC2249CT-ND	Panasonic	ECJ-2FB1C105K	C11,C9	1uF, 16V	capacitor, 0805
1	Digikey	PCC272BNCT-ND	Panasonic	ECJ-2VB1H272K	C84	2.7nF, 50V	Capacitor, 50v, 0805
5	Digikey	PCE3061CT-ND	Panasonic	ECE-V1CS100SR	C59,C60,C29,C43,C42	10uF, 16V	aluminum cap, SMD
3	Digikey	PCE3182CT-ND	Panasonic	ECE-V1CA101WP	C56,C58,C55	100uF, 16V	aluminum cap, SMD
3	Digikey	PCE3185CT-ND	Panasonic	ECE-V1EA470UP	C62,C48,C61	47uF, 25V	aluminum cap, SMD
4	Digikey	PCF1238CT-ND	Panasonic	ECW-U1224KC9	C31,C36,C32,C35	0.22uF, 100V	capacitor, 2820
3	Digikey	PT10KXCT	Panasonic	ERJ-1TYJ103U	R34,R74,R33	10K, 1W	resistor, 2512
3	Digikey	PT10XCT	Panasonic	ERJ-1TYJ100U	R61,R62,R76	10K, 1W	resistor, 2512
2	Digikey	PT220XCT	Panasonic	ERJ-1TYJ221U	R73,R72	220, 1W	resistor, 2512
2	Digikey	ST32TB102CT-ND	BC Components	ST32TB102	R26,R27	1K	POTENTIOMETER
2	Digikey	ST32TB502CT-ND	BC Components	ST32TB502	R22,R21	5K	POTENTIOMETER
2	Digikey	TC7WH04FUTCT	Toshiba	TC7WH04FU(TE12L)	U3,U2	TC7WH04FU	TRIPLE INVERTER
2	Digikey	TC7WH08FUTCT	Toshiba	TC7WH08FU(TE12L)	U5,U4	TC7WH08FU	DUAL 2-INPUT AND GATE
1	Digikey	XN0431400LCT-ND	Panasonic	XN0431400L	Q13	XN04314	NPN PNP Transistor
1	Digikey	Z963-ND	Omron Electronics, Inc	G4W-2214PUSH-DC12	RLY1	SP Relay	DPST-NO RELAY, 15A
1	Digikey	ZXMN2A01FCT-ND	Zellex Inc.	ZXMN2A01FTA	Q11	ZXMN2A01	MOSFET, Nch
1	McMaster	98370A009	McMaster	98370A009		Flat Washer	flat washer for heat sink spacer
2	Newark	01H0485	Vishay / Dale	CRCW20104642F100	R1,R2	46.4K, 1W	resistor, 2010
2	Newark	01H0495	Vishay / Dale	CRCW20105621F100	R10,R15	5.62K, 1%, 1W	resistor, 2010
2	Newark	03B2235	United Chemi-Con	SMG50VB10RM5X11LL	C46,C47	10uF, 50V	aluminum cap
3	Newark	03B2235	United Chemi-Con	SMG50VB10RM5X11LL	C3,C4,C5	10uF, 50V	aluminum cap
1	Newark	13F4038	TYCO ELECTRONICS-EMT&B	TT11AG-PC-1	S1	switch	SPDT 3P Switch
4	Newark	20C1977	Vishay / Dale	WSR-2.05< 1%	R38,R37,R75,R79	50mOHM, 2W	power resistor, 2W
4	Newark	31F2160	SPC Technology	WLS-04-017-SZ		Lock Washer	Lock Washer, #4
2	Newark	33C9527	AVX	BF074E0224J	C33,C37	0.22uF, 100V	capacitor, box
2	Newark	33C9531	AVX	BF074E0474J	C51,C52	0.47uF, 100V	capacitor, box
4	Newark	46F4081	Aavid Thermalloy	4880		To-220 mounting kit	To-220 mounting kit, Type4880
2	Newark	66F9123	Vishay / Dale	CRCW20101001F100	R5,R3	1K, 1W, 1%	resistor, 2010
4	Newark	67F4119	HH Smith	8423		Standoff	standoff, HEX threaded, L=0.5"
2	Newark	95C2482	Vishay / Dale	TNPW08051001RT9	R4,R6	1K, 0.1%	resistor, 0805
2	Newark	95C2483	Vishay / Dale	TNPW08051002BT9	R16,R11	10K, 0.1%	resistor, 0805
1	Newark	95C2488	Vishay / Dale	TNPW08051101BT9	R86	1.10K	resistor, 1%, 0806
1	Newark	95C2485	Vishay / Dale	TNPW08051022BT9	R87	10.2K	resistor, 1%, 0805
2	Digikey	P6.8KACT-ND	Vishay / Dale	ERJ-6GEYJ682V	R45,R44	6.8K	resistor, 0805
4	Newark	95F4579	United Chemi-Con	SME63VB471M12X25LL	C39,C40,C38,C41	470uF, 63V	aluminum cap

1	ACT	IRJHWS D AMP Ref3.5			IRAUDAMP1_REV3.9_BOM	PWB	Printed Wiring Board
1	Soldermask	15x15 Top/Bottom Stencil					
0	unstuffed	unstuffed			R40,R39,R53,R54,R55,R57,R58,R59,R56,R60,C50,C49,C30,C34,C22,C19,C7,C6,D10,D11,D13,D12		

Inductor Spec

Part number: NPT0104

Inductance: 18uH

Rated Current: 10A

Core: T106-2, Micrometals

Wire: AWG18, magnet wire

of Turns: 37

Finish: Varnished

Mechanical Dimensions:

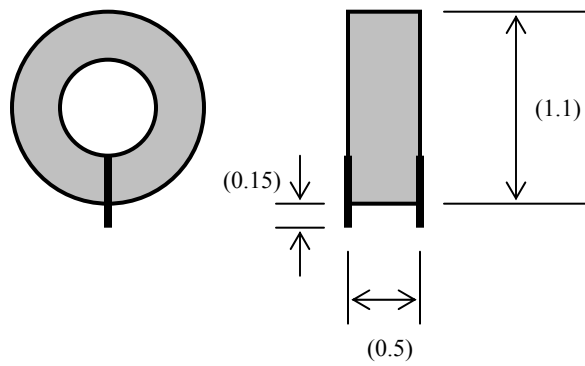

PCB layout

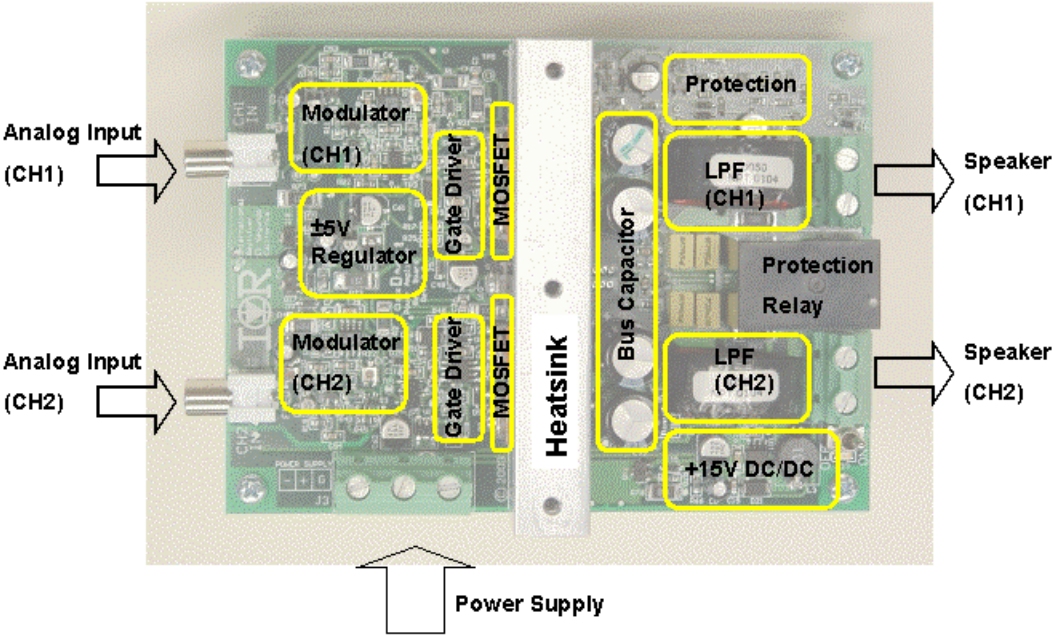

Functional Allocation

Mechanical Drawings

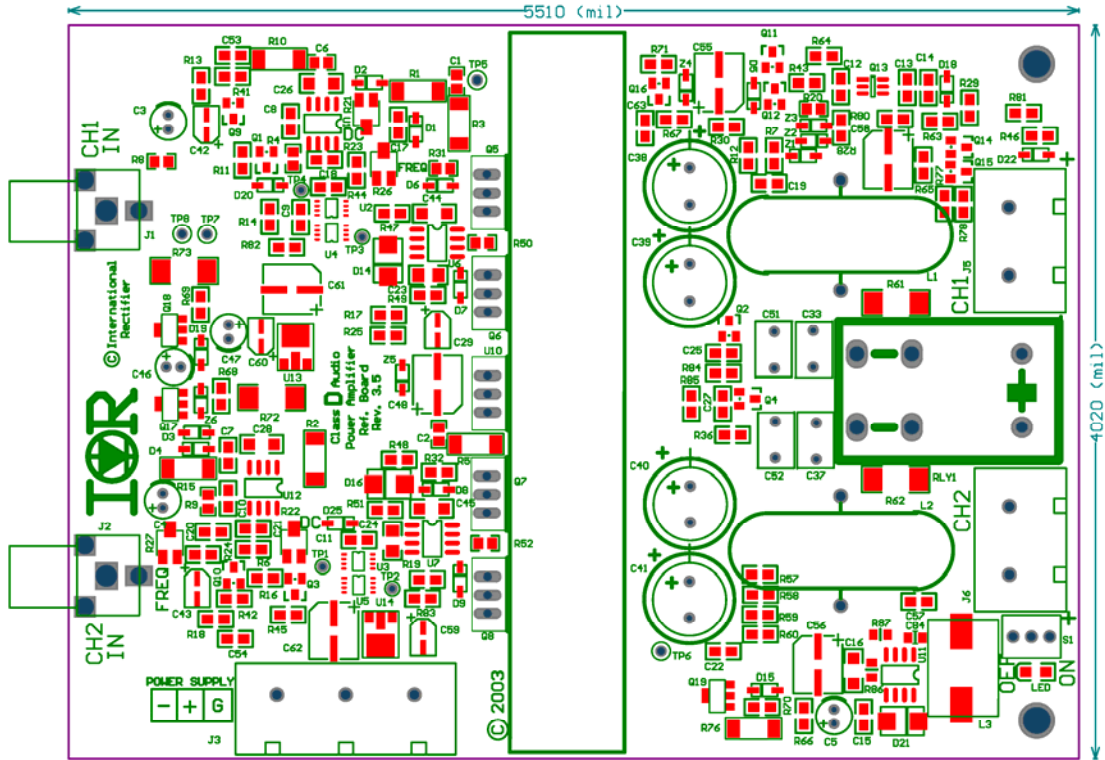

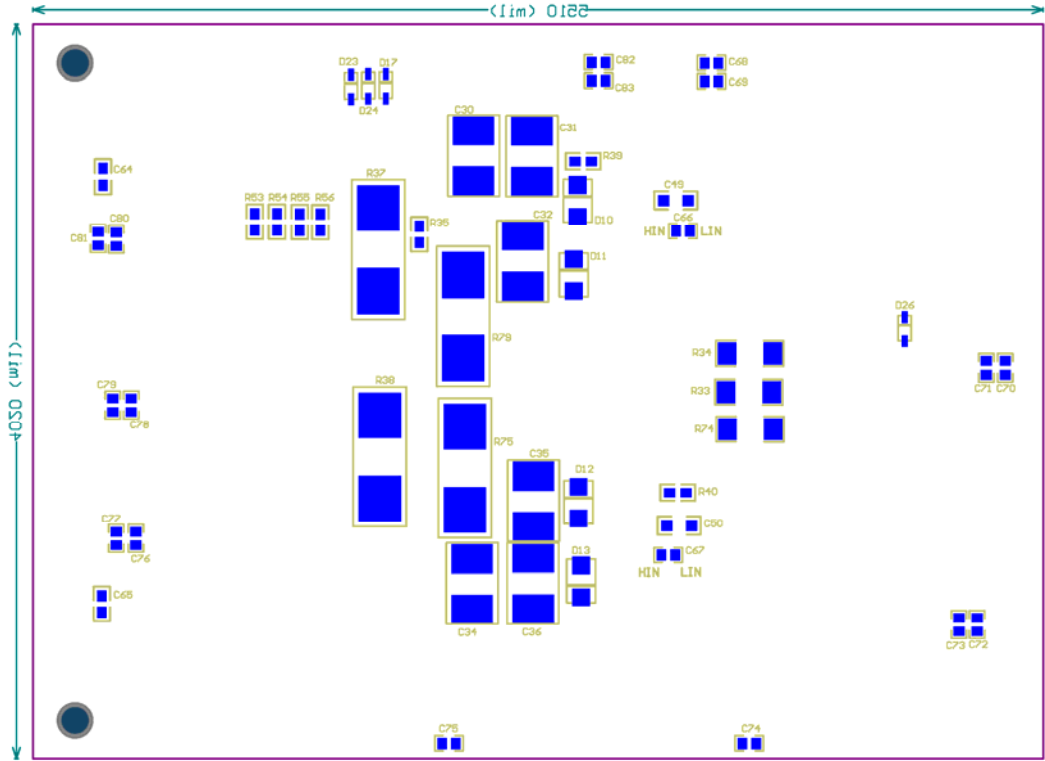

APPENDIX

A. OCP Trip Level

The trip level for CH-1 is given by

$$I_{TRIP} = \frac{V_{BE}}{R37} \cdot \frac{R35 + R84}{R84}$$

where $V_{BE}=550\text{mV}$ for $T_a=25\text{ }^\circ\text{C}$

In order to provide a flexible trip level, $50\text{m}\Omega$ of R_s is chosen. This is sensitive enough to sense a low trip level of 11A peak with $R84$ removed. As an initial setting, $R35$ and $R84$ are set to provide a trip level of 20A peak, which is large enough to have a loading of 370W (THD=1%) into 4Ω or 500W (THD=10%). The peak current does not increase as power goes higher when THD hits 1%. This is because only the rms value can increase as the peak value is limited by the DC bus voltage.

Peak load current I_{PEAK} for the given output power P_{out} is

$$I_{PEAK} = \sqrt{2} \cdot \sqrt{\frac{P_{out}}{R_{LOAD}}}$$

B. Voltage Gain

The voltage gain is set to be 18dB , which requires 3.4V_{rms} input to obtain 100W into 8 ohm . The voltage gain can be changed by modifying the value of $R10$ (CH-1) and $R15$ (CH-2). One thing that should be noted when these resistance values are changed is that the lower corner frequency formed by the input coupling capacitors $C3$ and $C4$ are also changed. $C3$ and $C4$ may have to be increased when the gain is increased in order to maintain the low end frequency characteristic.

The corner frequency is given by

$$f_{c_{LOW}} = \frac{1}{2 \cdot \pi \cdot R10 \cdot C3} \text{ [Hz]}$$

Please also note that the gain can be lowered if the source impedance is not negligibly low compared to $R10 / R15$.