

# Liquid-cooled power amplifier

by I. L. Stefani and R. Perryman

The amplifier to be described in this article was developed as part of a research programme in which it was employed to excite magnetic specimens. The original model was designed to produce peak currents slightly in excess of 10 amperes at frequencies ranging from zero to 5kHz, but operating experience indicated that the equipment was capable of being uprated by a substantial amount, and it is thought that publication of the constructional details might be of use to workers in other fields.

The need to operate with d.c. and at very low frequencies indicated that some form of transistor bridge should be used, and after one or two simple air-cooled arrangements had been tried, it was decided to experiment with liquid cooling. The first tests used power transistors mounted in pairs in two water-filled copper tanks, and while this arrangement enabled the ratings to be raised by some 30%, the onset of thermal runaway was rather sudden and it was felt that the small increase in output was a poor return for the extra complications. The tests proved to be useful, however, as they pointed the way to a more satisfactory form of liquid cooling. The following points were noted:

Natural circulation was slow and hard to start.

Stagnant layers of fluid collected round the transistors.

Relatively large thermal gradients appeared to exist in the transistor cases.

As a result of these observations a new series of tests was undertaken with the output transistors mounted in such a way that each received a turbulent flow of liquid close to the active element. Forced circulation and a fan-assisted heat exchanger were also incorporated, although flow from a tap was found to be very effective.

The electrical circuit was initially designed round two complementary pairs of emitter-followers connected so that each pair formed one half of a bridge, but it was subsequently thought that performance could be improved if the output elements were used as current-boosters assisting emitter-followers of lower rating. A scheme of this type was employed by I. Hardcastle and B. Lane' and its success influenced the final

decision to adopt this arrangement. Difficulties were encountered with output voltage stabilization and with the design of a gain control which did not cause a shift in the d.c. balance at the output. These points will be taken up later.

Various liquids were considered for the coolant, but the final choice was water with a little "Prestone" inhibitor added.

### output stage

The general layout of the liquid-cooled output stage is shown in Fig. 1. Cool liquid is pumped into a small tank to equalize the pressure applied to the branches and the coolant is then passed through four short lengths of polythene tubing to the transistor bank. After cooling the transistors the warm fluid is returned to another tank from which it flows to a fan-assisted heat exchanger of the type commonly used for car heating. The complete fluid circuit is outlined in Fig. 2. Fig. 3 shows the constructional details of the flow and return tanks which are identical except for the lengths of the inlet and outlet pipes. The transistor mountings are cut from  $\frac{1}{4}$ in brass plate to sizes given in Fig. 4, which also shows the manner of bending the pins and the construction of the cover plate. The skewing of the bent portions of the pins prevents contact between adjacent transistors when they are mounted in a bank. Before assembly, leads should be soldered to the pins, and the brass surfaces should be sealed with a little "Silcoset" sealing compound. Great care should be taken when sealing the transistors to the mounting blocks for if any seepage occurs in the regions of the base pins, the high current gains will make the booster stage virtually uncontrollable. Normal motor gasket sealing compounds have not been found to be satisfactory.

When the amplifier is operating, cool liquid is pumped into the lower tank where

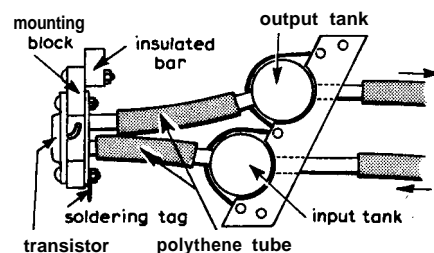

Fig. 1 Mechanical layout of liquid-cooled power output stage

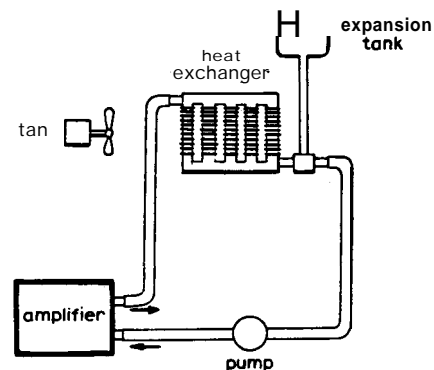

Fig. 2 Complete cooling circuit

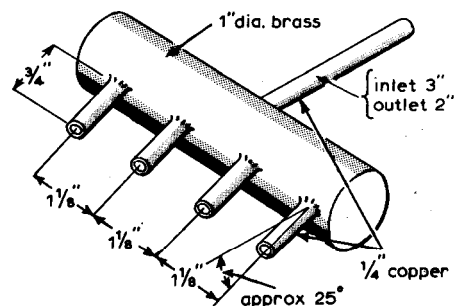

Fig. 3 Dimensions and constructional details of flow and return tanks.

1. High power amplifier. I. Hardcastle and B. Lane. *Wireless World*, Oct. 1970, p. 417.

it divides into four streams, each stream passing through a  $\frac{5}{16}$  in dia. hole in the mounting block to strike the transistor at a point immediately opposite its active element. The water subsequently passes up the  $\frac{3}{32}$  in wide slot to the  $\frac{1}{4}$  in diameter exit hole and back to the return tank.

**The output circuit**

The operation of the output stage may be readily understood by reference to Fig. 5, which shows emitter-followers Tr2 and Tr3 supplying a small current to a load. The resistors R2 and R3 have little effect on the performance of the transistors other than to cause a slight reduction in their maximum voltage swings, but the voltages developed across these resistors may be used to operate current boosters in the form of complementary power transistors Tr4 and Tr5. The collector of each booster acts as a current source and forces a large current into the load without substantially altering the voltage drop associated with the emitter-follower. Thus the load current is large and the effective source impedance

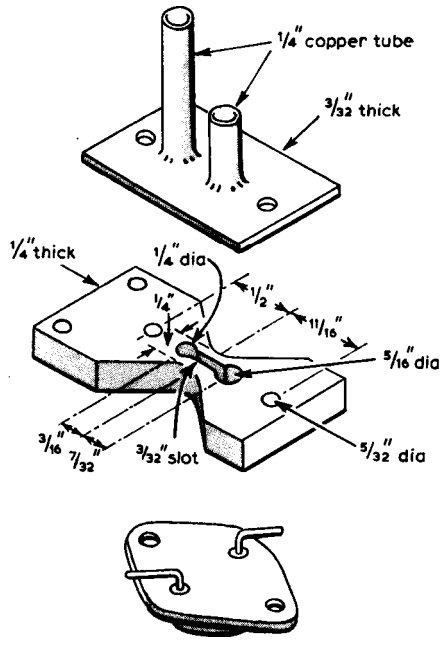

Fig. 4 Dimensions of transistor mountings.

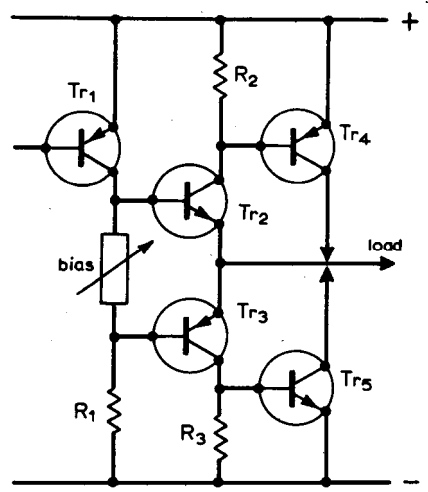

Fig. 5 Elements of the output circuit.

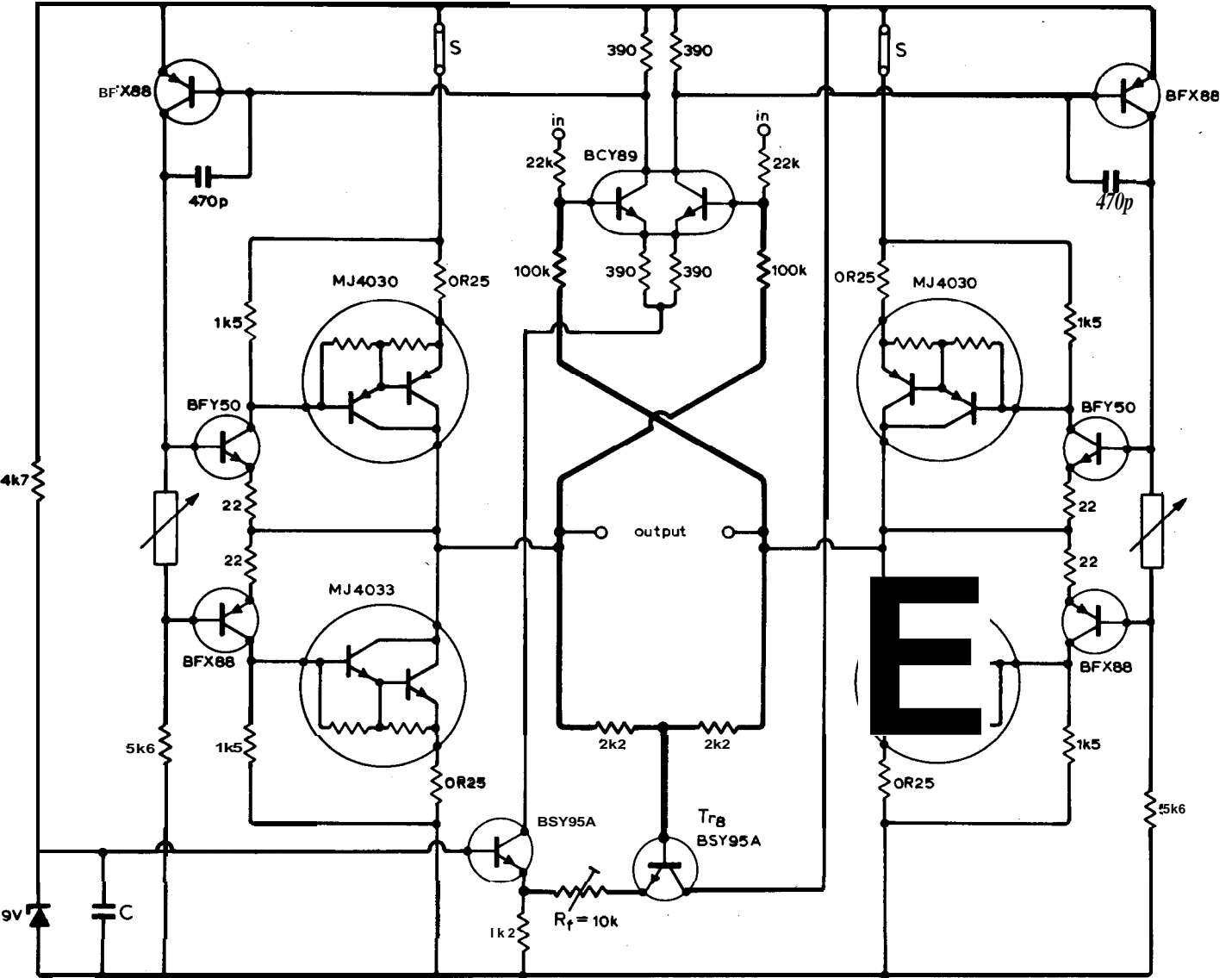

Fig. 6 Circuit of the complete output bridge.

is low. In the actual amplifier the transistors  $T_r$  and  $T_5$  are replaced by Darlington-pairs mounted in TO3 cases. This raises the sensitivity so that the booster operates directly from low power driver and output stages built into a printed circuit. When two output and booster stages are connected together to form a pair of bridge arms, the biasing of the emitter-follower bases requires the provision of a constant-voltage circuit capable of being preset to give an output between 1.2 and 1.5 volts. This biasing circuit is used to adjust the standing current passing through the power transistors which form the bridge arms. (See Fig. 5.) The complete output bridge is shown in Fig. 6.

### The driving stages

The transistors driving the emitter-followers must be operated with their emitters joined to one of the supply busbars or it will not be possible to provide sufficient voltage swing to operate the bridge properly. (See Fig. 5.) This means that the driving stages are prone to drift and some means of correcting this tendency must be devised. The method used is the application of feedback in two separate forms: first, the mid point of the output is stabilized via (Fig. 6)  $T_r$  and resistor  $R_f$  which regulate the standing current passing through the input stages, and second, conventional voltage or parallel feedback is used. The feedback circuits are drawn in heavy lines in Fig. 6, which shows the basic arrangement of the power stages. The 470pF capacitors connected to the driving stages prevent high frequency instability and emitter resistors in the booster stages produce a certain amount of thermal stabilization. The  $0.25\Omega$  resistors have to carry large currents and they are constructed from short lengths of Eureka wire wound into helical coils.

Finally, in order to facilitate setting up, it is advisable to insert manganin shunts or removable links in the bridge arms at S for monitoring the standing currents. The amplifier now in use has small ammeters permanently connected to manganin shunts.

### The preamplifier

The duties of the preamplifier are three-fold. First, it is required to provide a voltage gain, and second, it should enable this gain to be varied. Finally it must convert the single-ended input to a balanced output. The first and third functions present no difficulties, but the second is a possible source of trouble as the d.c. passing through the gain control produces a voltage drop which alters with the setting and is considerably magnified in passing through the amplifier. Matched f.e.t.s were tried out in the controlled stages but the degree of balance did not prove sufficient to prevent severe drift with changes of temperature. The final arrangement used a rheostat to partially short-circuit the output of a carefully balanced double-transistor amplifier stage. The mean voltage drop using this scheme is independent of the control setting. The circuit, with component values,

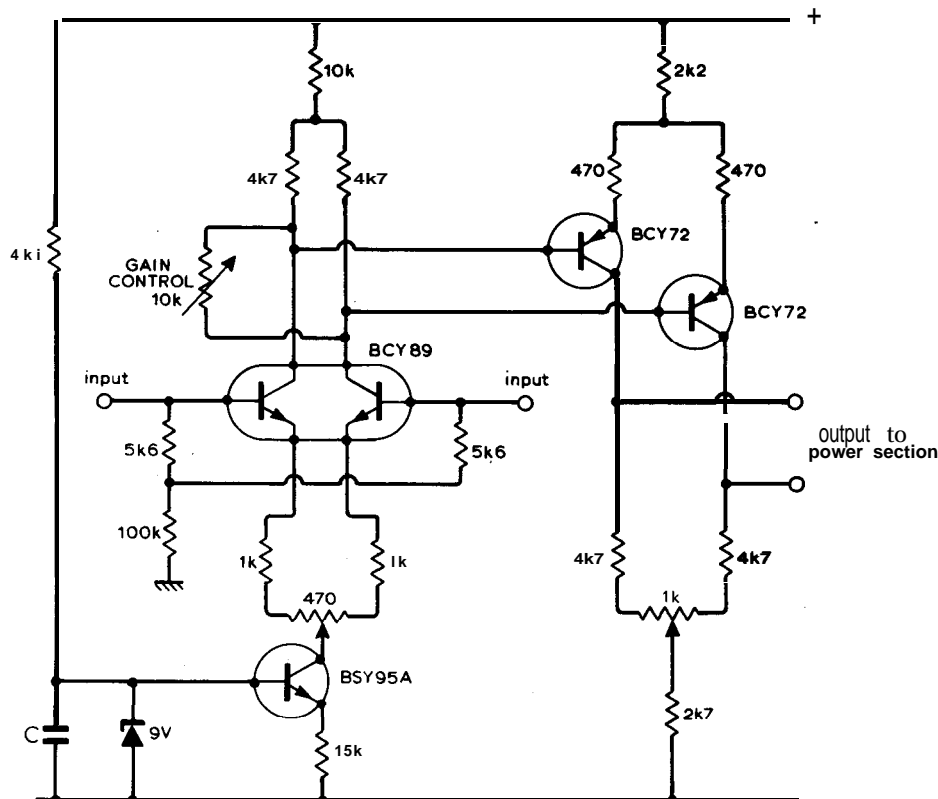

Fig. 7 Preamplifier circuit.

is shown in Fig. 7.

**Setting up and testing:** With water flowing through the output boosters and the  $10k\Omega$  bias trimmers turned right back, the supply voltage should be turned on and the feedback resistor  $R_f$  adjusted until the mean output voltage is about 15V for a 30-volt supply. The gain control should then be turned to the short-circuited position and the  $1k\Omega$  balance control on the preamplifier adjusted until the voltage between the output terminals shows zero on a d.c. voltmeter. When the gain is turned to a maximum this voltage will usually change and it should be returned to zero by means of the  $470R$  balance control. The bias controls should then be carefully turned clockwise until currents of 1 to 2A flow in each of the pairs of bridge arms. After allowing the stage to warm up the trimmers should be rechecked. Exhaustive testing has not been carried out because the amplifier has been in continual use for well over a year, but a few test results are given as an indication of the performance.

Max. open circuit voltage swing when using a 32V d.c. supply: 58V (20.5V r.m.s.)

Max. output current swing (limited by the power unit): 34A (12A r.m.s.)

Max. power: greater than 230W

Output impedance: less than  $0.5\Omega$

Frequency range: approximately 0-10kHz

For general use it is advisable to install some means of protection. Possibly a flow-operated switch and thermocouples on the transistor mounting blocks should be considered.

Finally, it should be recorded that the amplifier in its present form does not heat up very much. This suggests that it might

be possible to uprate the design by a substantial margin, the simplest method would appear to be to raise the supply voltage and adjust some of the circuit component values accordingly.

## Sixty Years Ago

It always seems a pity when legendary phenomena are explained in terms of modern scientific theories, and many people would ascribe this iconoclastic trend to the last 30 or 40 years. But it seems that we were at it long before that, as witness this extract from the December, 1914 issue of *The Wireless World*, in which W. B. Cole implies that Joshua was a bringer of "bad vibes".

... it seems quite clear to the writer that Moses, who was learned in all the wisdom of the Egyptians, imparted to his successor Joshua the knowledge of the principle of resonance, and that Joshua, discovering that the wall of Jericho responded to a certain note, made use of this principle.

"During the week he kept his men busy walking round the city in order to keep the inhabitants within (verse 1). The Israelites were strictly enjoined to maintain silence, so that the priests who blew with the trumpets might make the necessary acoustical experiments, and to tune all their trumpets to the same pitch. The seventh day all was ready. The people completely encircled the city and at a given signal the priests blew with their trumpets, the people shouted, the same note, and the effect of this choir of 40,000 men (Josh. iv, 13) caused the wall to collapse."

---

---

## LIQUID-COOLED POWER AMPLIFIER

---

---

I have studied with great interest Messrs Stefani and Perryman's liquid-cooled power amplifier design (December 1974 issue) and have come up with a few questions.

Have they experienced problems with the power output short-circuiting through the water coolant? (I would assume the "Prestone" inhibitor is to increase corrosion resistance, not decrease conductivity.)

Why have they used MJ4030 and MJ4033 transistors, which can dissipate up to 150 watts each at  $25^{\circ}\text{C}$ ? When using water cooling they could probably have used lower power and therefore probably cheaper Darlington pairs (e.g. MJ900 and MJ1000s which, incidentally, have an  $h_{FE}$  of about 6000 at  $I_C=3\text{A}$  d.c. as opposed to 3500 at 10A d.c.).

What is the input sensitivity to the pre-amplifier for the rated output?

Apart from possibly changing one or two transistors (such as the BSY95A) for higher voltage equivalents (for example BSY54), would any other components need to be changed to run at (say) 50 volts supply?

Paul Lenartowicz,  
Hounslow,  
Middlesex.

*Dr Perryman and Mr Stefani reply:*

*No* problems have been experienced with leakage currents through the water. The resistance of the water will be of the order of  $1\text{k}\Omega$  and this provides only a slight additional load. However, if any water escapes near the input pins of the transistors the whole stage becomes inoperative and damage may result. Mr Lenartowicz is correct in assuming the purpose of the "Prestone" is to act as an inhibitor of corrosion and organic growth.